

**// YOUR RELIABLE PARTNER
FOR RENDERING AND BIOMASS
TECHNOLOGY.**



Press+LipidTech

hf-press-lipidtech.com

// ECOLOGICAL SUSTAINABLE RECOVERY OF HIGH-QUALITY ANIMAL PROTEINS AND FATS.

HF Press+LipidTech provides proven technology for processing biomass material. Reliability and efficiency are the core features of our products. As an experienced partner, HF P+LT offers all essential components from single spare parts to machines:

- // SCREW PRESSES
- // DISC DRYER
- // MEAT PULP COLLECTING VESSELS
- // STERILIZER
- // SPARE PARTS

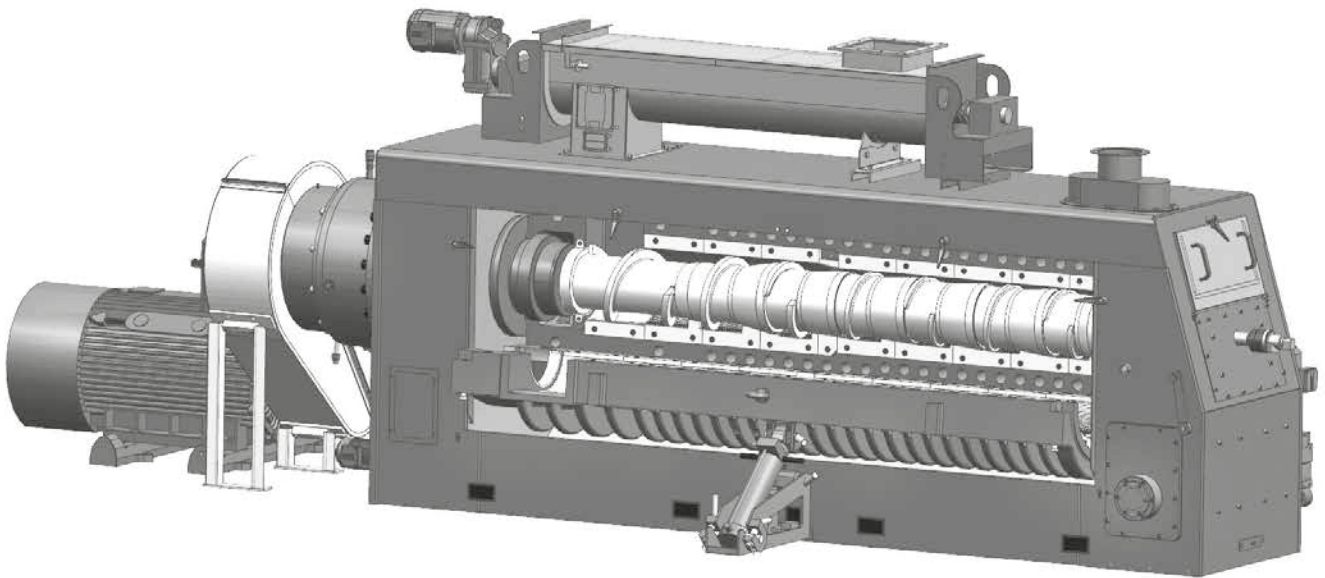

// SCREW PRESSES

SP 160-280R

Screw presses are used for mechanical extraction of fats from dried semi-finished products. The self-centering, free-floating shaft of the presses assure secure operation, and the operator-friendly design enables optimum access for easy maintenance and exchange of spare parts (e.g. cage bars).

Nevertheless, not only the press design but also dedicated geometries and customized solutions are important. Due to more than 150 years of ex-

perience in mechanical engineering and pressing applications, portable operation at the highest standards is guaranteed.

FEATURES

- Longest service life of wear parts (reduced downtimes)
- Energy saving drive systems
- Online press monitoring
- Optional cake-breaking device
- Shear pin and safety coupling solutions to separate the drive from the press – most advanced hard facing technology
- Screw press from the proven SP-press family for processing dried semi-finished product
- Simple design for easy operation and optimum access for maintenance
- Self-centering, free-floating shaft

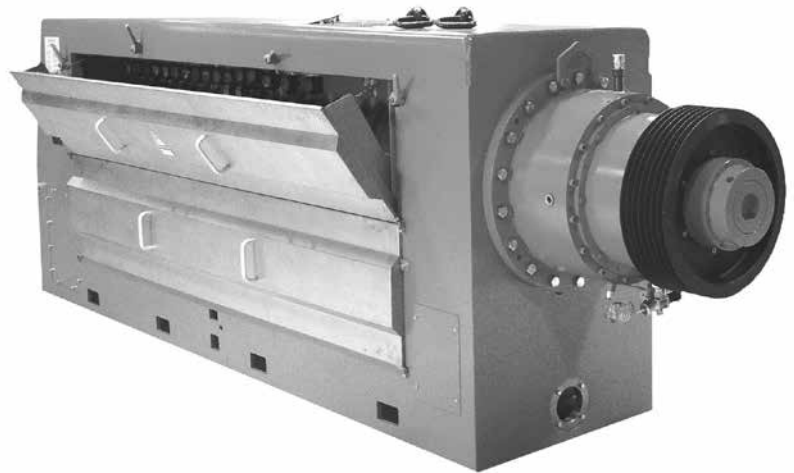

TECHNICAL DATA

Type	SP160R	SP220R	SP280R
Total length screw press (mm)	3,440	4,550	5,210
Total width screw press (mm)	1,160	1,360	1,780
Total length strainer cage (mm)	1,600	2,200	2,800
Main drive motor (kW)	45	110-132	160-200
Total net weight (mt)	8,500	11,000	16,000
Raw material acceptance, slaughterhouse waste and animal carcasses (t/h)	1.5-3.5	09-11	14-17
Dried semi-finished product (t/h)	0.6-1.4	3.4-4.2	5.3-6.5

// DISC DRYER

100-400 m²

Due to indirect heating and appropriate arrangement of the rotor, the HF disc dryer guarantees optimal, uniform drying of sticky and difficult drying materials. The hollow disc agitator and the hollow discs are heated by steam and realize highly efficient water evaporation.

The disc dryer is suitable for different feed material, such as slaughter offal, animal carcasses, municipal and industrial sludge, rape (canola) seed, corn gluten, etc. and can also be used as a cooker and heater.

FEATURES

- Low operating costs
- Long operating life
- Stainless or mild steel possible

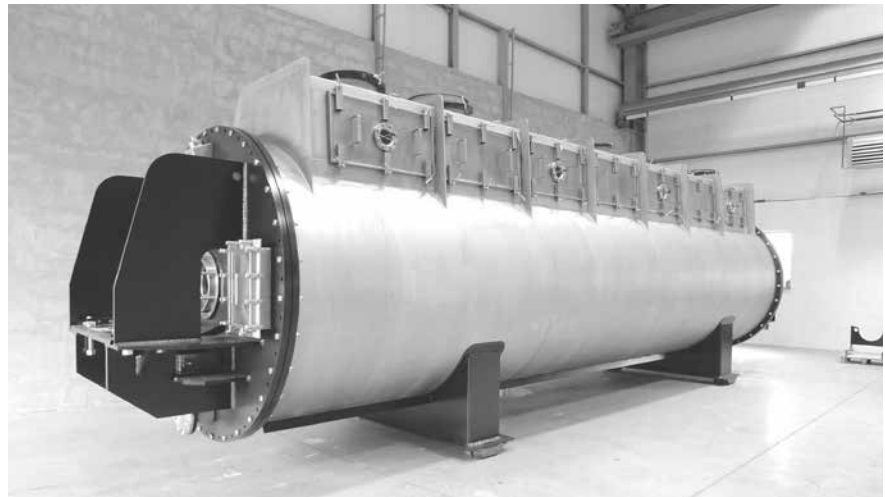

TECHNICAL DATA

Series	Heating surface	Pressure	Drive	Ø Stator	Height stator	Length stator
	(m ²)	(bar)	(KW)	(mm)	(mm)	(mm)
HF 100	100	6-10	75	1,680	2,800	6,100
HF 200	200	6-10	90	1,930	3,050	7,860
HF 300	300	6-10	110	2,180	3,200	8,625
HF 400	400	6-10	132	2,400	3,250	8,975

// MEAT PULP COLLECTING VESSELS V20-V100

The meat pulp collecting vessels are the ideal temporary storage vessels for sterilized meat pulp for the optimum combination of batch and continuous processes. The horizontal vessel is equipped with an agitator, but can also be implemented with the double jacket for heating if desired.

FEATURES

- Capacities: 20-100 m³
- Stainless or mild steel possible
- Tailor-made design according to customer's requirements



// STERILIZER

E2000-E7000

The HF sterilizers are the best products for the optimal thermal treatment and sterilization of all kinds of animal byproducts. The horizontal pressure vessel can also be designed and operated as a dryer or hydrolyzer for feathers. The jacket and the agitator are heated by steam and thereby guarantee consistent mixing and heating of the material.

FEATURES

- Suitable for different feed materials, e.g. fats and tallow
- Service-friendly
- Stainless steel or mild steel possible
- Capacities: 5.0-15.0 m³
- Heating surfaces: 40-80 m²

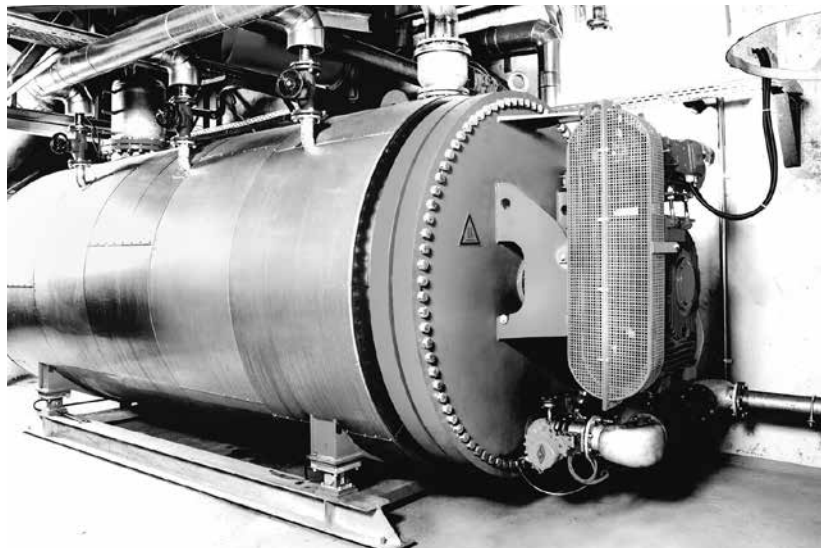

TECHNICAL DATA

Series	E2000	E5000	E6000	E7000
Drive (kW)	37	55	55	75/90
Total length (mm)	7,200	8,600	6,100	9,750
Total height (mm)	1,850	2,100	2,250	2,300
Outer diameter (mm)	1,500	1,800	2,100	2,000
Capacity (mt/h) processed as sterilizer/dryer	0.875-1.6	1.5-4.0	2.0-4.0	2.0-5.0
Capacity (mt/h) processed as sterilizer/extractor	0.5-0.8	0.8-1.5	1.0-1.7	1.2-2.0
Weight (kg)	13,700	20,300	25,000	31,300
Heating surface incl. agitator (m ²)	40	60	40-70	80

HF Press+LipidTech
Schlachthofstrasse 22
21079 Hamburg
T: +49 40 77179-0
service-plt@hf-group.com
hf-press-lipidtech.com

A BRAND OF
 **FoodTech Group**