

**// YOUR RELIABLE PARTNER
FOR YOUR OILSEED AND
EDIBLE OIL PROCESSING.**



Press+LipidTech

hf-press-lipidtech.com



// YOUR EXPERT IN OILSEED PRESSING FOR DECADES.

For more than 160 years, HF, located in Hamburg, Germany, has always focused on engineering, dedicated solutions, and integrated production resulting in reliable equipment with process know-how.

Ever since the company was first established, HF has been dealing with oilseed processing in its many facets. Today HF focuses on delivering customized solutions to the edible oil industry, and delivers a complete portfolio of oil seed preparation, oil seed pressing, crude oil cleaning, and crude oil refining solutions worldwide! HF's equipment has gained a lot of attention during its affiliation to KRUPP. The product portfolio also includes special presses and apparatuses for animal waste products or special applications in the dewatering sector. Our global customers are using their long-lasting HF equipment to produce high quality products under the most efficient and cost competitive conditions.

HF is fully owned by the L. Possehl & Co. GmbH, a group of over 150 medium-sized industrial companies located around the world. Each company is encouraged to preserve and maintain its unique identity and to continue developing independently within the Possehl Group. As a successful and diversely positioned group since 1847, the Possehl name stands for entrepreneurship, tradition, and responsibility.

An important part of our companies' culture is the Possehl Foundation. The Possehl Foundation was created upon the passing of Emil Possehl (son of the original founder of the Possehl Group) in 1919. His last will & testament formed the foundation to ensure that attention would continue to be paid to the improvement of the community, historical buildings, and to the education of youth.

HF is proud to be part of the financially stable and socially responsible Possehl Group.

// YOU KNOW YOUR REQUIREMENTS. WE HAVE THE SOLUTIONS.

Are you looking for high performance from a proven supplier for your edible oil needs? The HF Press+Lipid-Tech is the world's leading and most innovative partner in the sector of machineries and complete systems for oilseed processing and crude oil refining, and thus the right partner for you!

FEATURES & BENEFITS

The combination of our long history of designing and delivering oilseed and edible oil processing plants and machineries based on innovative German engineering provides you with many benefits. Here are just a few of them:

- Easy operation, minimum product loss, highest product quality
- High reliability
- Easy and efficient production control
- Optimal pressing performance
- Low maintenance
- Tailor-made solutions
- 24-hour service
- Proven energy saving systems



// FROM SEED TO HIGH QUALITY PRODUCTS – EVERYTHING FROM ONE SOURCE.



// REQUIREMENTS ARE DIVERSE.

WE DESIGN TO MEET YOUR NEEDS.

The first systems for oilseed processing left our production halls more than a century ago. Since that time, we can look back on more than 2,000 presses in the screw press sector.

Low-maintenance machines with extremely high throughputs and pressing performances make sure that you save money, perhaps not straight away, but definitely in the long run.

Our top priorities lie in the reliability and low-maintenance aspects of our machines. By producing sensitive and critical parts in our own manufacturing facilities, we are always able to guarantee the best possible quality. Deliveries of components from our suppliers are subject to particularly stringent quality control inspections.

// OIL SEED PROCESSING AND REFINING TECHNOLOGY ALL OUT OF ONE HAND.

Pressing of different kinds of seed several procedural and qualitative aspects need to be taken into consideration to guarantee the best possible pressing result.

Whether the sensitive seed is being prepared by mechanical or thermal means, the decisive factor lies in correct design and selection of the system. This is crucial to the overall result and, ultimately, to your economic success.

HF is always the right partner for:

- Full-pressing plant
- Pre-pressing plant
- Cold pressing plant

Refining vegetable crude oils from a pressing plant or extraction plant, a series of process steps is involved. HF has developed own technologies following the specified conditions in order to be able to provide the user with systems that are cost-effective and highly operational reliable, efficient, and easy in operation. From crude oil to edible oil with state-of-the-art, innovative HF technology.

HF is always the right partner for:

- UF Degumming Plant
- Neutralization Plant
- Combined Process
- Bleaching Plant
- Winterization Plant
- Deodorization Plant

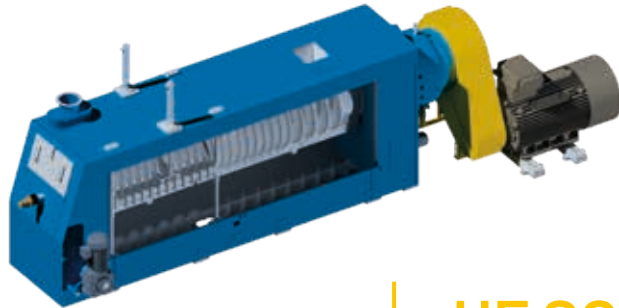

HF SCREW PRESSES

SP series for superior
pressing technology

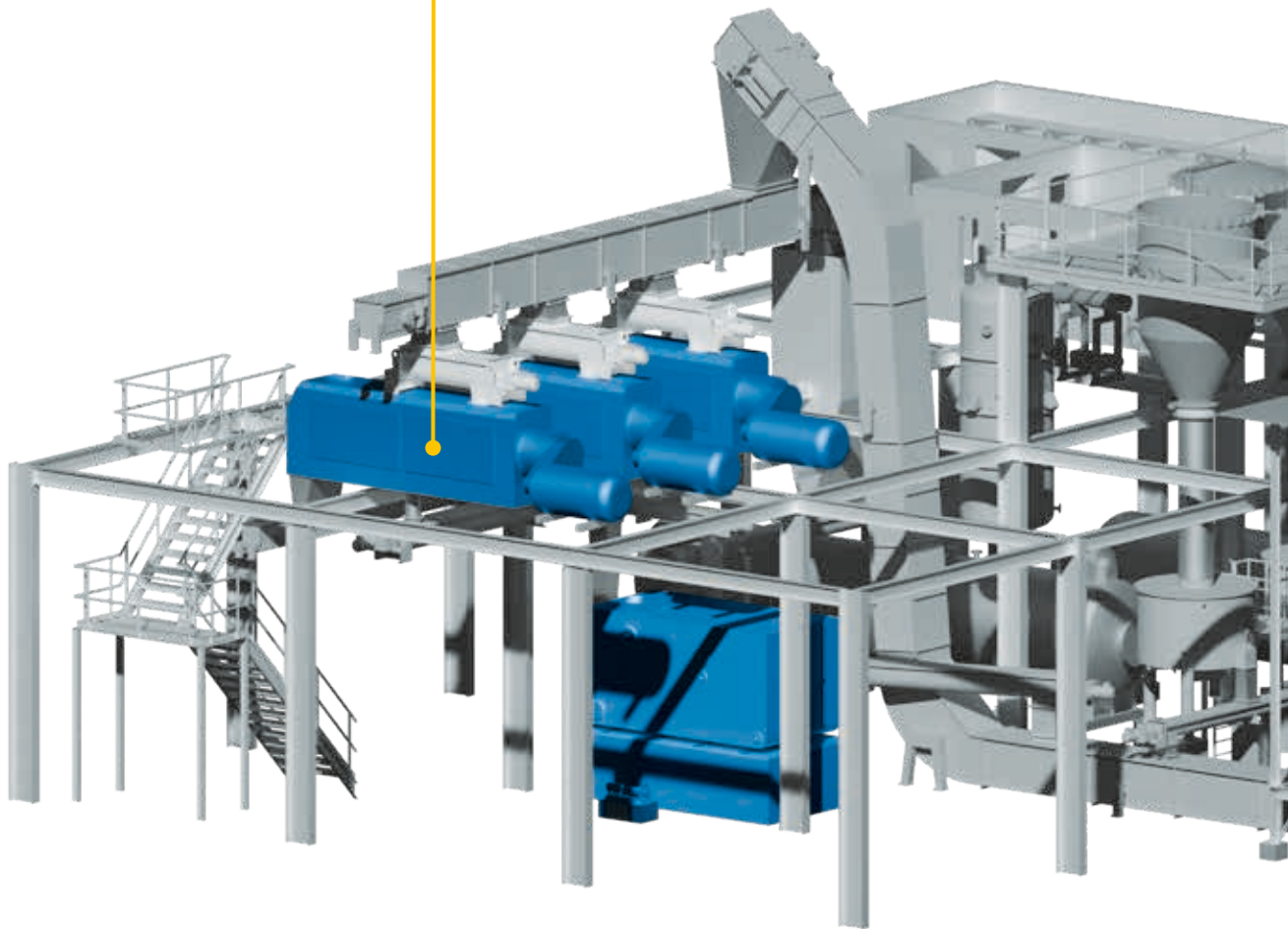



HF CONDITIONING TECHNOLOGY

Guarentees excellent drying efficiency

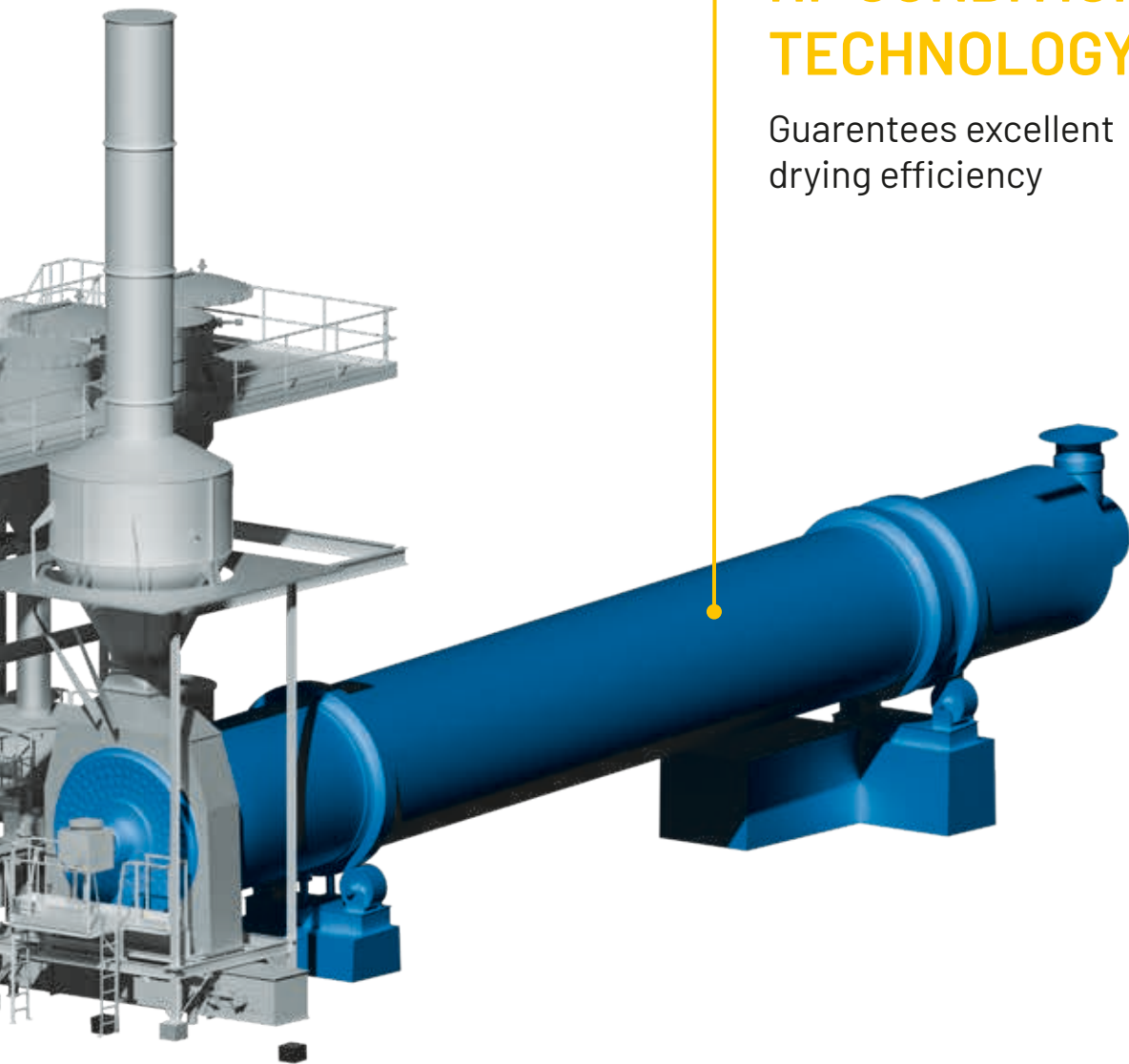

**// GETTING THE BEST
OUT OF YOUR SEEDS
IS OUR AMBITION.**



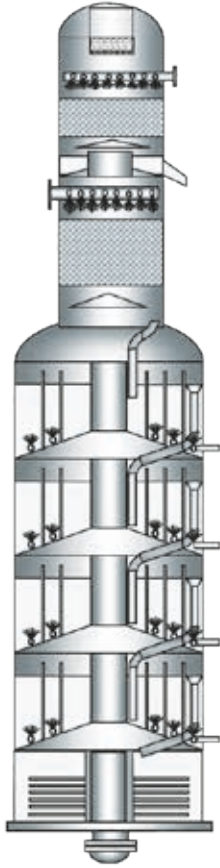

HF DEODORIZER

Minimal stripping steam consumption and maximum efficiency due to shallow bed technology

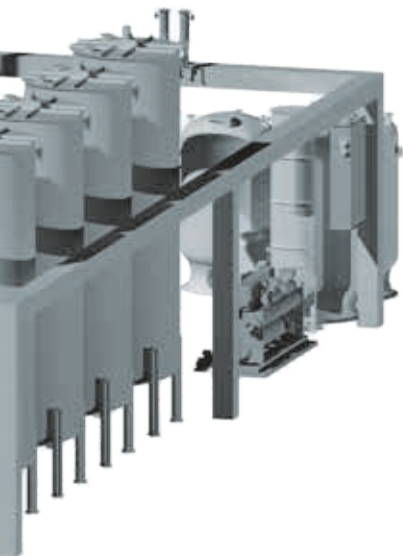

// SCREW PRESS MANUFACTURING CENTER.

Complete coordination of the manufacturing, assembly, and delivery of our presses takes place at our factory in Croatia (owned by HF since 1998). There we have a highly skilled work force working 24/7 and a modern facility, including the latest precision machine tools to ensure top quality components.

Manufacturing process

The manufacturing process begins with proper tracking of all parts required for the respective order.

Whether it is an electrical component, or steel, all parts are logged through and into our logistics center. This ensures that all parts required for the order are ready when needed and are checked through our quality control.

HF-specific parts run through our state-of-the-art welding and machine shop. All welded parts are stressrelieved to ensure top and long term quality. All parts are finalized by our skilled personnel on any of our large number of modern machine tools.

The press is assembled in our assembly floor where all our main assembly groups are individually built by dedicated teams for the respective components, ensuring top quality and repeatability.

// CUSTOMER SERVICE.

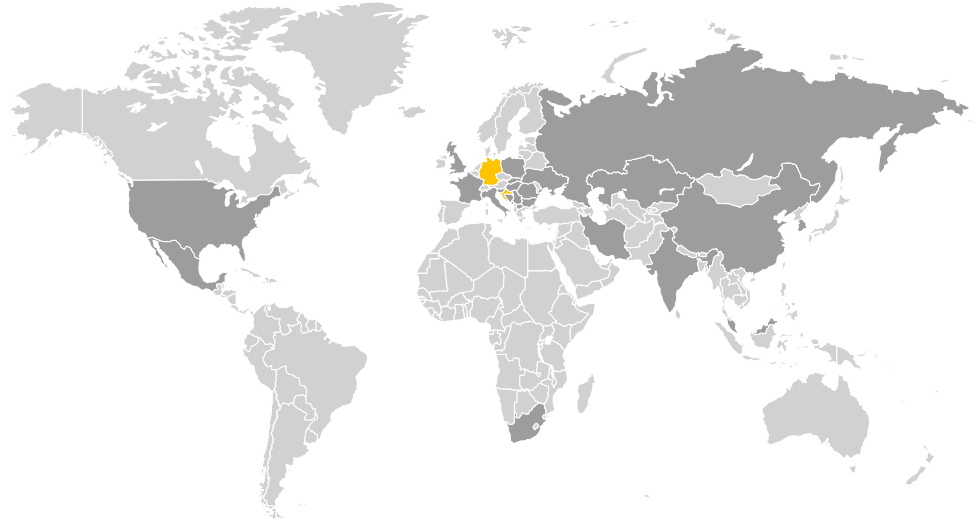

Satisfied customers in 40 countries
More than 2,250 installed systems in the screw press sector 2,000 employees of the HF GROUP from 20 nations.

Supplier Integrity

Our clients depend on our machines 24 hours a day, seven days a week. Our systems are extremely reliable and very low in maintenance in every respect, provided that all wear and tear parts are inspected regularly and exchanged when necessary. We are constantly working on improvements for our machines so that your factory will remain technically state-of-the art.

Site Installation Services

We are available to support you with the installation & commissioning of your new or relocated presses to ensure the most efficient start-up of your equipment. We work closely together with your key users to enable you to install presses on your own, if preferred.

Spare Parts

We will always have parts available for your system. Essential wear parts are mainly manufactured in our factory in Valpovo. These quality parts are designed to be long lasting, so that the functionality of your system is guaranteed over the entire life cycle of the press.

Maintenance/Optimizations

We provide more than just support in system design, assembly, and commissioning. We offer a wide range of maintenance and consulting services, particularly during running operations. Our team of experts can provide analysis of your systems, identifying any areas with improvement opportunities, and can propose the necessary measures required to optimize your operation.

Please find further and detailed information on our "services & maintenance" for your equipment either on our website: hf-press-lipidtech.com or in our service brochure "Premium Spare Parts, Services, Maintenance and Consulting".



Use the fastest access to our webshop with the QR code.

You can place orders quickly and conveniently.

You always have an overview of your orders.

You have access to those spare parts which are relevant to you based on your personal customer profile.

You receive an overview of machines created individually for you.

// THE HF SERVICE TEAM ALWAYS FOCUSING ON YOUR NEEDS!

We provide more than just support in machine design, assembly, and commissioning. Overall maintenance concepts are an essential part of our scope of supply.

Maintenance Concept

- Customized spare part packages
- Supervision & equipment audits
- Increased reliability & reduction of unscheduled downtime
- Sustainable cost savings and safe & fast supply

Full maintenance concepts

- Screw press
- Flakers & Conditioners
- Gearboxes

The exchange frequency depends on the service life of the spare parts and on a working hours-based analysis with a strong correlation with the processed material and the system specifications. Our full maintenance concept is not a rigid framework, but rather a customized program for your individual requirements, and will be tailored to you.

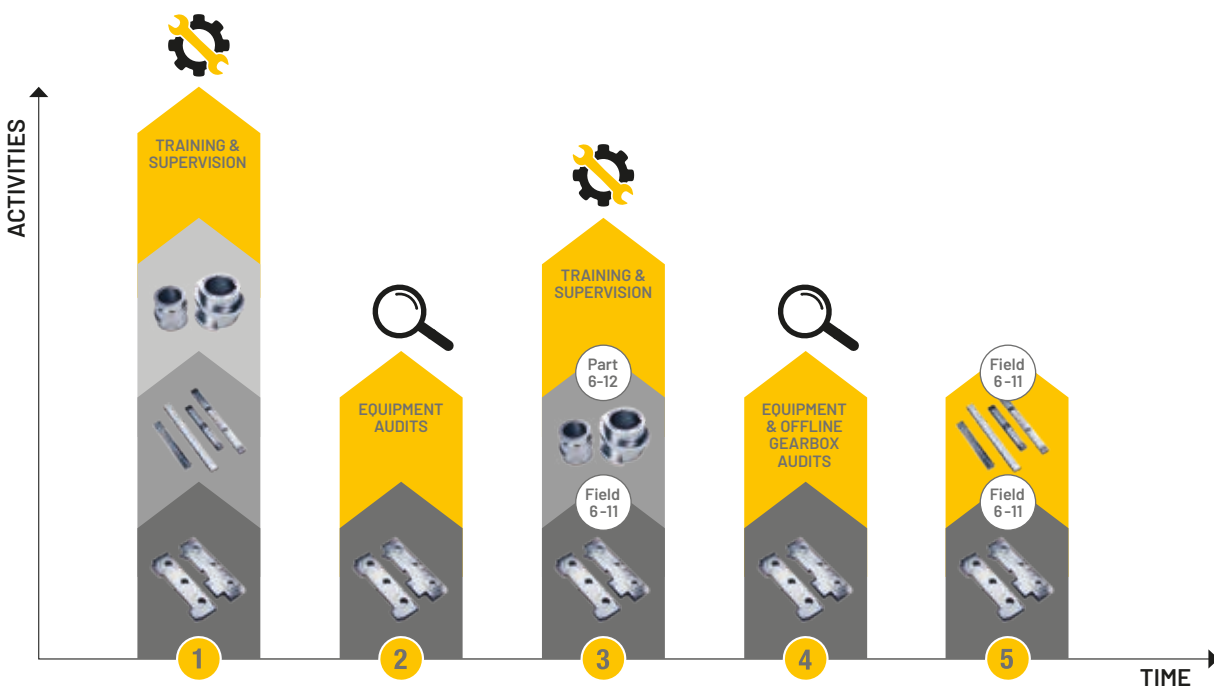



HF Press+LipidTech
Schlachthofstrasse 22
21079 Hamburg
T: +49 40 77179-0
service-plt@hf-group.com
hf-press-lipidtech.com

A BRAND OF
 **FoodTech Group**